

INTREPID™ UniZone™

PLUG-AND-DEPLOY FENCE DETECTION SENSOR



Offering unprecedented ease of use, **INTREPID™ UniZone™** is a high-performance, standalone perimeter fence detection sensor designed to reliably and cost-effectively protect smaller critical infrastructure sites vulnerable to terror attack, sabotage, asset theft or liability risk.

Based on Southwest Microwave's field-proven MicroPoint™ smart-sensor technology, UniZone™ protects up to 200 linear meters (656 linear ft) of fence line, and consists of a UniZone™ Fence Detection Sensor mounted to the fence or in a nearby control room, and a single MicroPoint™ sensor cable tie-wrapped to the fence or topper to detect cut/climb attempts.

UniZone™ employs advanced **Point Impact Discrimination™** to monitor activity along the cable in 1.1 meter (3.6 ft) increments, analyze the characteristics of each disturbance and reliably detect cut or climb intrusion attempts while ignoring harmless environmental disturbances. Superior system intelligence and powerful digital signal processing successfully mitigate risk of site compromise while delivering the lowest nuisance alarm rate in the industry.

As a plug-and-deploy detection sensor, the UniZone™ set-up process is simple. A laptop USB connection configures and calibrates the system via user-friendly Installation Service Tool (IST) software. LED indicators are provided on the sensor to identify Power Input, Alarm Status, Fault Notification and Sensor Disturbance. Isolated, on-board relay contacts provide intrusion and fault alarm indication.

Unlike conventional sensors, which offer only one detection sensitivity setting per alarm segment, UniZone™ employs a proprietary software-based calibration process - **Sensitivity Leveling™** - to account for variations in fence fabric or tension and optimize detection sensitivity in 1.1 meter (3.6 ft) increments along the sensor cable. The result is uniform intrusion detection along the entire protected fence line.

KEY FEATURES

- QUICK, EASY SET-UP & DEPLOYMENT
- ADVANCED DIGITAL SIGNAL PROCESSING
- POINT IMPACT DISCRIMINATION™ PREVENTS ENVIRONMENTAL NUISANCE ALARMS
- SENSITIVITY LEVELING™ FOR UNIFORM DETECTION ALONG FENCE LINE
- OPERATES IN HARSH ENVIRONMENTS
- INSTALLS ON MOST FENCE FABRIC
- EMI / RFI SHIELDING & SURGE PROTECTION
- MONITORING VIA ON-BOARD FORM-C RELAY OUTPUTS

APPLICATIONS

- Communications & Cellular Towers
- Well Heads & Water Reservoirs
- Fuel Storage Tanks
- Pumping & Compressor Stations
- Pipeline Block Valves
- Electric Substations & Switchyards
- Railway Power Transformers
- Bridge Footers
- Storage Facilities / Cages & Construction Sites
- Critical Inner Perimeter Elements

INTREPID™ UniZone™

PLUG-AND-DEPLOY FENCE DETECTION SENSOR

PRINCIPLES OF CALIBRATION & DETECTION

The intelligent UniZone™ Fence Detection Sensor monitors activity along the MicroPoint™ sensor cable in 1.1 meter (3.6 ft) increments. This data is used during the patented Sensitivity Leveling™ calibration process to bring each section of fence to the same detection sensitivity, regardless of fence fabric or condition. This prevents the hot spots that trigger nuisance alarms in conventional sensors.

To initiate detection, the sensor sends a pulse down the cable using the principles of Time Domain Reflectometry (TDR). The pulse is reflected back by a disturbance to the fence, causing the sensor to alarm if an intrusion attempt is detected. Harmless distributed disturbances are ignored.

SENSITIVITY LEVELING™

A calibration walk is performed to optimize detection sensitivity within each 1.1 meter (3.6 ft) cell by accounting for variations in fence fabric or tension. A sensitivity profile is then generated across all cells and the alarm threshold is set.

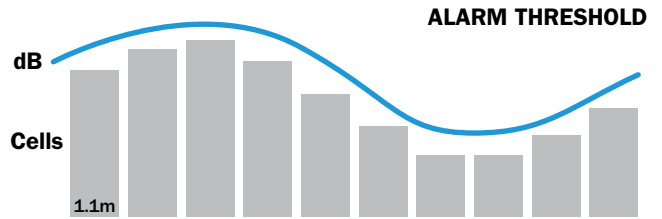

RELIABLE DIFFERENTIATION BETWEEN INTRUSION ATTEMPTS AND ENVIRONMENTAL DISTURBANCES

PERIMETER FENCE

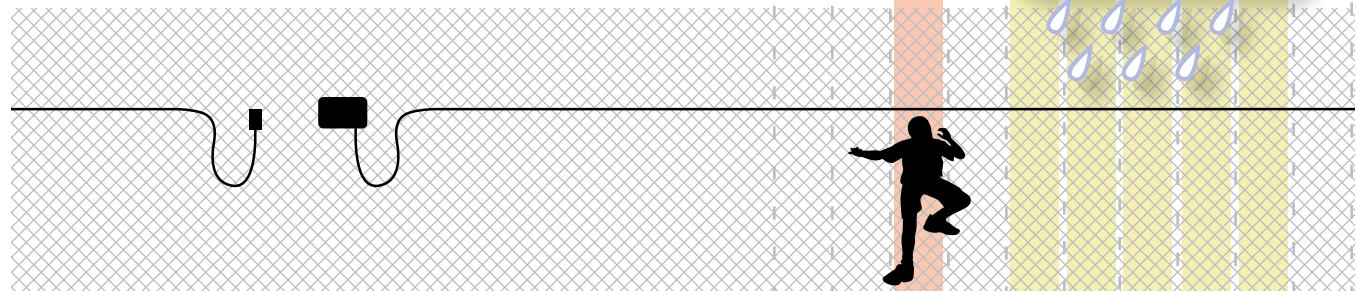

When a target makes contact with the fence, the received signal is sampled to create a signature which describes the reflected pulse.

Digital Signal Processing measures the characteristics of this pulse, differentiating between a Point Impact (cut or climb attempt) and a Distributed Disturbance (rain, wind, vehicle traffic).

If the target is recognized as a Point Impact and exceeds the alarm threshold, an alarm is declared. Distributed disturbances are ignored, preventing nuisance alarms.

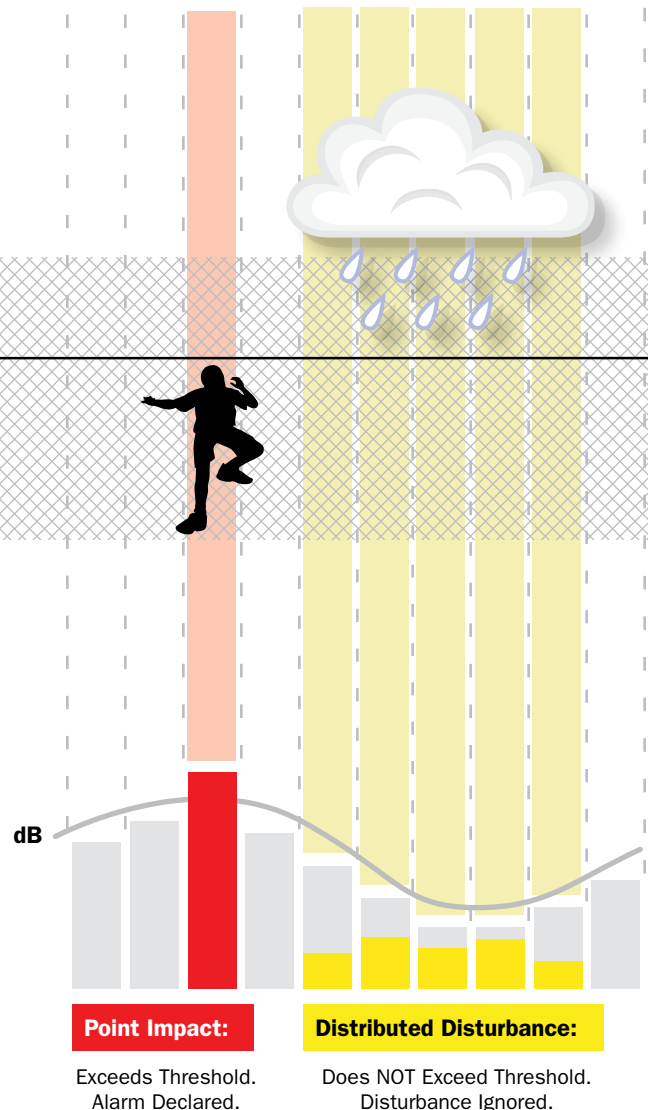

FEATURES AND BENEFITS

■ POINT IMPACT DISCRIMINATION™

Identifies localized attempts to cut or climb the fence, but ignores distributed fence noise generated by wind, rain or vehicle traffic – solving nuisance alarm problems that plague conventional fence sensors.

■ SENSITIVITY LEVELING™

This proprietary calibration process accounts for variations in fence fabric or tension to provide uniform detection sensitivity along the fence line.

■ PLUG-AND-DEPLOY CONVENIENCE

Attach the MicroPoint™ cable to the fence and mount the UniZone™ sensor on the fence or in a nearby control room. Configure the sensor via user-friendly UniZone™ Installation Service Tool software and a quick calibration walk to achieve a custom Sensitivity Profile that optimizes detection and prevents nuisance alarms.

■ RUGGED CONSTRUCTION

Heavy-duty, tampered industrial enclosure resists rain, snow, UV radiation and mechanical abuse. Connections are equipped with high energy surge arrestors. Sensor circuit board is 100% shielded against extreme sources of EMI and RFI, protected against lightning-induced surges and 1 mm conformal coated to enable reliable operation in 100% humidity, corrosive atmospheres or harsh climactic extremes.

■ MOUNTS ON MOST FENCE MATERIAL

MicroPoint™ cable installs easily on chain link, welded mesh, expanded metal and other fence fabric, as well as on barbed or razor wire. Fence condition is not critical and different fence types may be protected within the same system as a result of UniZone's proprietary Sensitivity Leveling™ calibration process.

TYPICAL UNIZONE™ CONFIGURATION DIAGRAM

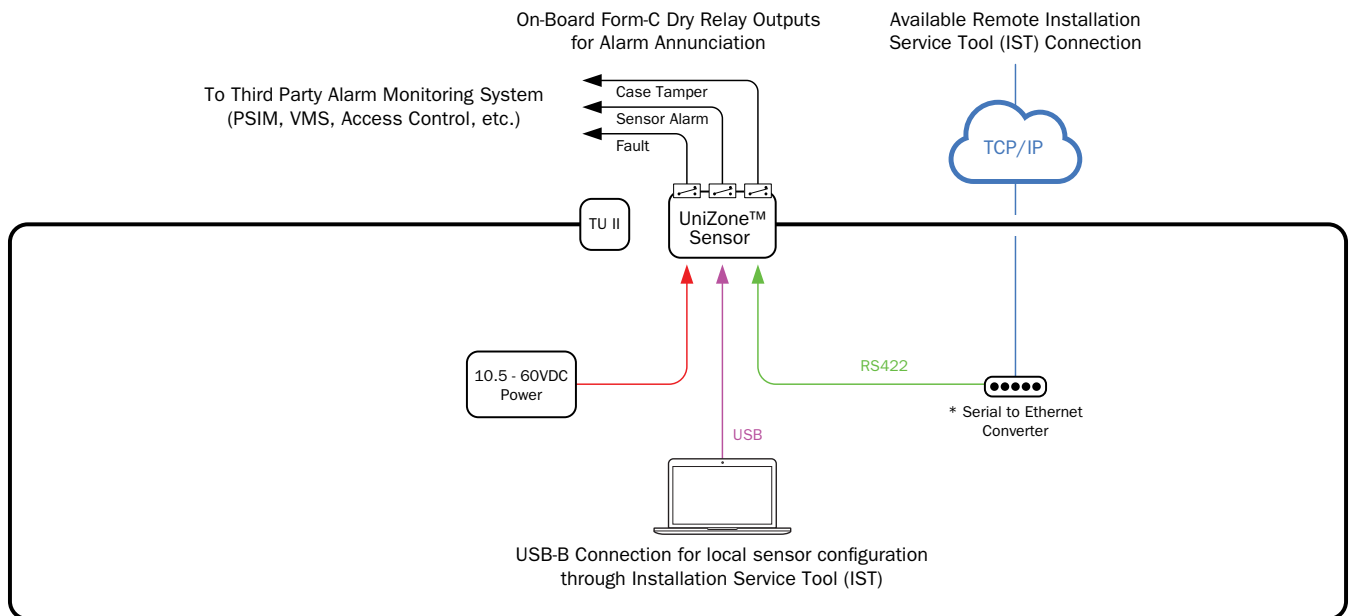

Maximum 200 Linear Meters (656 Linear Feet) Per UniZone™ Fence Detection Sensor

FLEXIBLE GATE PROTECTION

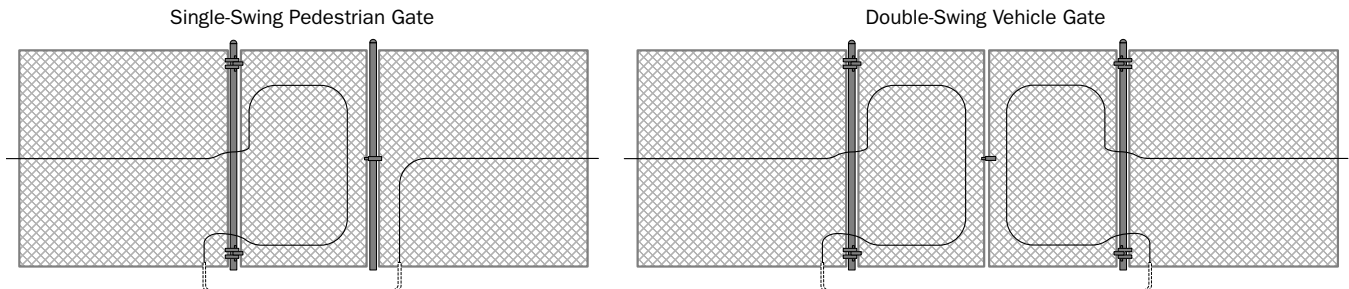

UniZone's rugged, flexible MicroPoint™ cable can be easily mounted to protect swing gates, and will withstand ongoing repetitive gate openings/closures. To prevent nuisance alarms, sections of cable may be easily disabled in software at driveways or pedestrian walkways and routed underground, without a need for splicing non-sensitive cable.

INTREPID™ UniZone™

SYSTEM COMPONENTS & SPECIFICATIONS



INSTALLATION SERVICE TOOL (IST)

INTREPID™ UniZone™ Installation Service Tool (IST) software graphically configures detection parameters and calibrates the system with laptop convenience at the UniZone™ Fence Detection Sensor via optically isolated, surge-protected USB-B connection. Sensor auto discovery, guided navigation and forward propagation simplify set-up.

Configuration security provides notification upon changes to device settings, ensuring that only approved changes are implemented.

Remote set-up and adjustment via RS422 or TCP/IP connection (using Serial/Ethernet converter) are also available.

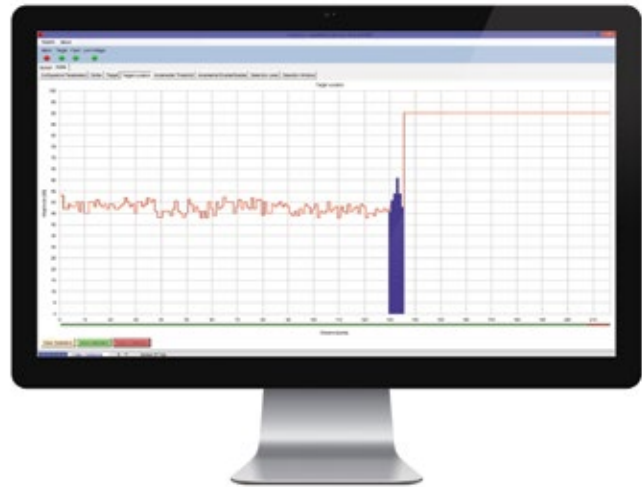

UNIZONE™ FENCE DETECTION SENSOR

Each UniZone™ Fence Detection Sensor processes data from a length of MicroPoint™ cable up to 220 m (722 ft) long, to protect up to 200 linear meters (656 linear feet) of fence line.

Housing: Tampered, weather-resistant ABS plastic.
NEMA-4, IP-65 performance.

Size: 268 H x 333 W x 108 D mm (8.59 x 13.11 x 4.26 in)

Weight: 1.81 kg (4 lbs)

Operating Temperature: -40° C to 70° C (-40° F to 159° F)

Power: 10.5 to 60 VDC at 4 watts

Current Draw: 12 VDC at 235 mA, 24 VDC at 130 mA,
48 VDC at 80 mA

Inputs: 1 MicroPoint™ cable

Ports: USB-B [1], RS422 [1]

Outputs: Alarm [1], Fault [1], Tamper [1]

SPDT-Form C, 2 amps at 28 VDC

MICROPOINT™ CABLE

MC-115 Type (Standard)

Size: 4.902 mm (0.193 in) diameter

Jacket: High density polyethylene, UV resistant, black.

Operating Temperature: -40° C to 70° C (-40° F to 159° F)

Minimum Bend Radius: 63.5 mm (2.5 in)

Packaged Size: **Packaged Weight:**

100 m (328 ft) 4 kg (9 lbs)

220 m (722 ft) 9.1 kg (20 lbs)

MC-315-Type (Armored)

Size: 6.45 mm (0.254 in) diameter

Jacket: High density polyethylene, UV resistant, black.

Operating Temperature: -40° C to 70° C (-40° F to 159° F)

Minimum Bend Radius: 63.5 mm (2.5 in)

Packaged Size: **Packaged Weight:**

100 m (328 ft) 15 kg (33 lbs)

220 m (722 ft) 26 kg (37 lbs)

TERMINATION UNIT II (TU II)

The Termination Unit II is used at the end-of-line to terminate the detection process.

Size: 133 H x 64 W x 76 D mm (5.25 x 2.5 x 3.0 in)

Weight: 0.45 kg (1 lb)

Operating Temperature: -40° C to 70° C (-40° F to 159° F)

Inputs: 1 MicroPoint™ Cable

ACCESSORIES

- Heavy Duty DC Power Supplies
- MicroPoint™ Cable Splice Kit (SU)
- Stainless Steel Weatherproof Enclosures
(Consult factory for details)



INTREPID™, MicroPoint™, UniZone™, Point Impact Discrimination™ and Sensitivity Leveling™ are trademarks of Southwest Microwave, Inc. Specifications subject to change without notice.

USA (CORPORATE HEADQUARTERS):
Southwest Microwave, Inc., Arizona, USA
Telephone +1 (480) 783-0201

EUROPEAN OFFICES:
Southwest Microwave Ltd., Worcestershire, UK
Telephone +44 1386 75 15 11

MIDDLE EAST OFFICES:
Southwest Microwave, Inc., Dubai, UAE
Telephone: +971 4 371 2624