

Southwest Microwave, Inc.

Security Systems Division

INTREPID™

Relay Output Module II

Technical Manual



Trademark Notice and Certifications

INTREPID, MicroPoint and MicroTrack are registered trademarks of Southwest Microwave, Inc. Copyright 1995 and 2011 Southwest Microwave, Inc. All rights Reserved.

Windows, XP, Vista, Word and Notepad are a registered trademark of Microsoft Corporation.

FCC Notice

This device complies with FCC Rules Part 15. Operation is subject to the following two conditions:

This device may not cause harmful interference and

This device must accept interference received, including interference that may cause undesired operation.

This equipment has been tested and found to comply with the limits for a Class A digital device, pursuant to part 15 of the FCC Rules. These limits are designed to provide reasonable protection against harmful interference when the equipment is operated in a commercial environment. This equipment generates, uses, and can radiate radio frequency energy and, if not installed and used in accordance with the instruction manual, may cause harmful interference to radio communications. Operation of this equipment in a residential area is likely to cause harmful interference in which case the user will be required to correct the interference at his own expense.

CE Notice

This equipment has been designed and tested to EN61000-6-2:2005 and EN61000-6-4:2006 per Directive 89/336/EEC.

RoHS Compliant

Copyright Southwest Microwave, Inc. May, 2015

**Southwest Microwave, Inc.
9055 South McKemy Street
Tempe, Arizona 85284-2946**

Tel: (480) 783-0201

Fax: (480) 783-0401

Email: infosd@southwestmicrowave.com

Web: www.southwestmicrowave.com

Table of Contents

- 1. Introduction4**
- 2. Hardware.....4**
 - 2.1 Relay Output Module II.....4
 - 2.2 Optional Power Supplies5
 - 2.3 Interconnections5
 - 2.4 Typical Configuration6
- 3. Configuration Switch/Jumper7**
 - 3.1 Introduction7
 - 3.2 Address Switch S1.....7
 - 3.3 CDT Jumper J2.....8
 - 3.4 Tamper Switch8

1.0 Introduction

The Relay Output Module II (ROM II) is part of the INTREPID™ family of products. It is available in two (2) configurations: *the ROM II-8 has eight (8) relay outputs and the ROM II-16 has sixteen (16) relay outputs*. Its function is to provide relay output contact closures to interface with alarm monitoring devices such as alarm panels or CCTV matrix systems. The ROM II is part of the INTREPID Series II (IPP II - INTREPID Polling Protocol II) communications format. Each output has an associated LED to indicate when the contact closure has an alarm condition. LED's are also provided for communications and power status. A system controller such as the Relay Control Module II (RCM II), Control Module II (CM II), Control Module II Networked (CM II-N), Graphic Control Module II-Heavy Duty (GCM II-HD), Perimeter Security Manager (PSM), Remote Polling Module II (RPM II) or Software Development Kit (SDK) is required to individually configure the outputs of the ROM II-8 or ROM II-16.

Each output has a Normally Open (N.O.), a Normally Closed (N.C.) and a Common (COM) position available at the terminal strips on the circuit board.

The ROM II communicates with other INTREPID Series II devices using RS422 communications. This communication can be done over 22 or 24 gauge stranded shielded twisted pair wire (max 5,000 feet [1,500m] between devices) or fiber optic devices. The address of the ROM II is set by a dip switch on the circuit board.

The ROM II-8 operates from 10.5 to 60 VDC @ 3.2 Watts with a minimum startup current of 375mA. The operating current with standard power supplies are: 12 VDC @ 205mA, 24 VDC @ 115mA and 48 VDC @ 65mA.

The ROM II-16 operates from 10.5 to 60 VDC @ 5.4 Watts with a minimum startup current of 600mA. The operating current with standard power supplies are: 12 VDC @ 360mA, 24 VDC @ 190mA and 48 VDC @ 105mA.

2.0 Hardware

2.1 Relay Output Module II (ROM II)

The ROM II is packaged in the standard INTREPID enclosure as shown in Figure 1. The dimensions are 5.5 in H x 13.5 in W x 5 in deep (14cm H x 34.3cm W x 12.7cm D). It weighs 2.5 lbs (1.1kg). The ROM II circuit board can also be installed in other enclosures.



Figure 1 – INTREPID Enclosure for ROM II

2.2 Optional Power Supplies

12 VDC power supply: Model PS13 Power Supply operates from 85-246VAC, 47-63Hz and furnishes 13.6 VDC at up to 2.8A. Power supplies contain automatic switchover and battery charging circuitry for optional standby batteries of up to 25AH. Temperature rated from 14° to 122° F (-10° to 50° C). UL, ETS, EMC, CE, RoHS compliant.

12 VDC power supplies: Model PS40 Power Supply operates from 120 VAC, 50-60Hz, 0.5A and furnishes 13.7 VDC at up to 1.6A. Model PS41 Power Supply operates from 220 VAC, 50-60Hz, 0.25A. Both contain automatic switchover and battery charging circuitry for optional standby batteries of up to 25AH and are fused on both input and output for maximum protection. Temperature rated from -40° to 150° F (-40° to 66° C).

24 VDC power supply: Model 78B1064 operates from 120VAC to provide 24VDC at 5A with 6.5AH battery backup. Includes; indoor enclosure 15 x 11 x 4 in. (381 x 280 x 102mm). Temperature rated from 32° to 122° F (0° to 50° C).

48 VDC power supplies: Model PS48 operates from 120VAC to provide 48VDC at 3A. Includes; indoor enclosure 14 x 12 x 4 in. (356 x 305 x 102mm). Model PS49 operates from 220VAC to provide 48VDC at 3A. *This supply does not include enclosure.* Temperature rated from 32° to 122° F (0° to 50° C). UL, CSA, TUV, CE compliant.

2.3 Interconnections

Figure 2 shows the various connection points, dip switches and diagnostic LED's available on the ROM II circuit board assembly. (Note: Figure 2 shows the ROM II-16. The ROM II-8 will not have relays K9 through K-16, terminal strip TB2 and associated electronic circuitry).

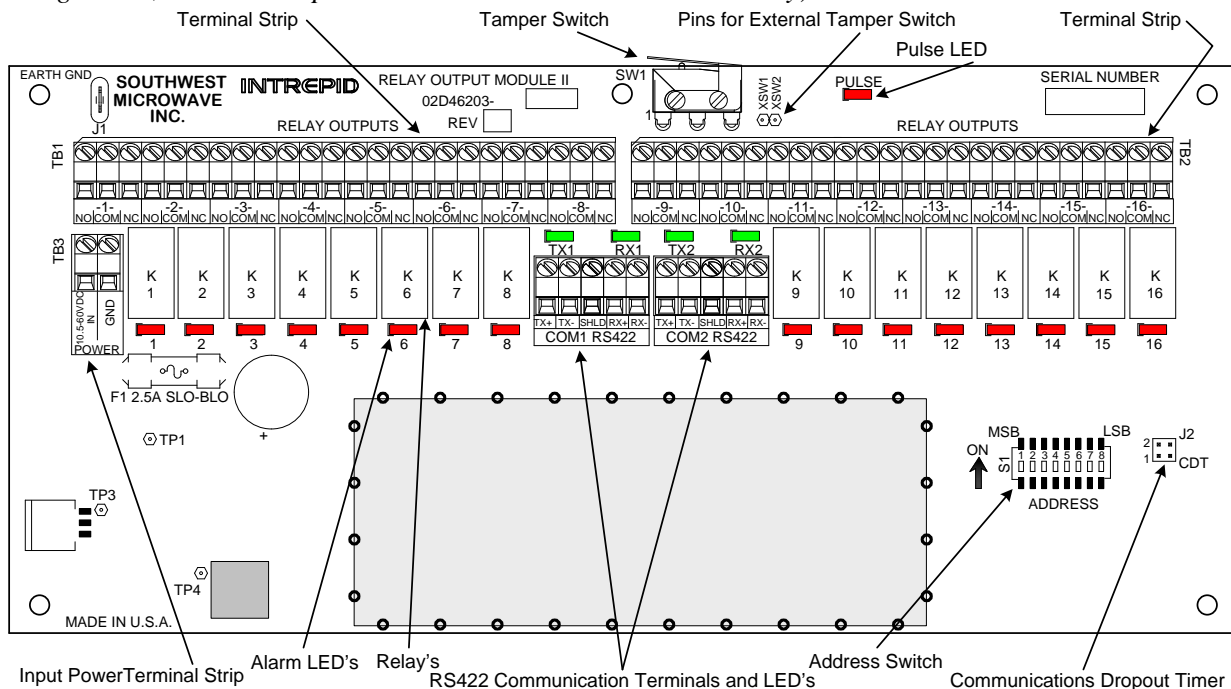

Figure 2 – Relay Output Module II-16 (ROM II-16) Circuit Card

Figure 3 shows the typical RS422 wiring diagram. This example uses the Relay Control Module II (RCM II) as the system controller connected to a Relay Output Module II-16 (ROM II-16), AIM II and a MicroTrack™ Processor II (MTP II). The AIM II and MTP II are located on the perimeter. The RCM II and the ROM II-16 are located in the control room for relay output interface to other control room devices.

The communications is RS422 and must use a 22 or 24 gauge twisted, stranded, shielded pair wire. Fiber optic devices can be used as well. Since this RS422 communications format is a point to point configuration, no termination device is required for the last unit on the line.

All the RS422 communications wiring is from the transmit side of one device to the receive side of the next device with the wiring from TX + to RX + and TX – to RX – as shown in Figure 3.

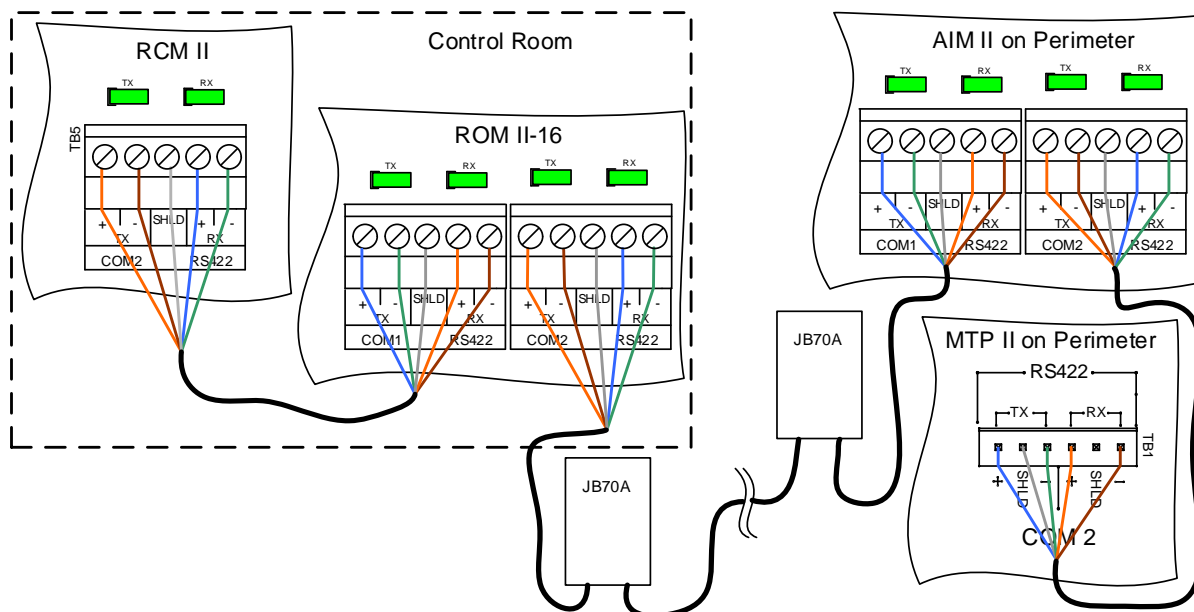

Figure 3 –ROM II Communications Wiring Diagram

2.4 Typical Configurations

Figure 4 shows a typical configuration using a RCM II, ROM II-16, AIM II, MTP II and a Microwave Link. The Control Room has a matrix switcher, lighting control system, paging system and an alarm panel. A computer is shown as the configuration/programming tool to set up the system (which is not required for system operation). A JB70A Surge/Lightning protection module is shown on the outside of the control room, at the AIM II and at the MTP II. The RCM II, ROM II-16, AIM II and MTP II are connected together with the RS422 communications line. The Microwave Link alarm relay and tamper switches are wired into the AIM II. The RCM II and the ROM II-16 are programmed so their relay outputs trigger inputs on the alarm panel, lighting control system, pager system and CCTV DVR/matrix. A UPS is also shown and is recommended for backup of the INTREPID™ products.

The AIM II can also be used as a stand alone multiplex system gathering alarm and tamper contacts from various devices such as microwave sensors or infrared sensors. Connected to a RCM II and ROM II-8 or ROM II-16, the inputs can be programmed to outputs that can be connected to alarm panels or other alarm reporting devices.

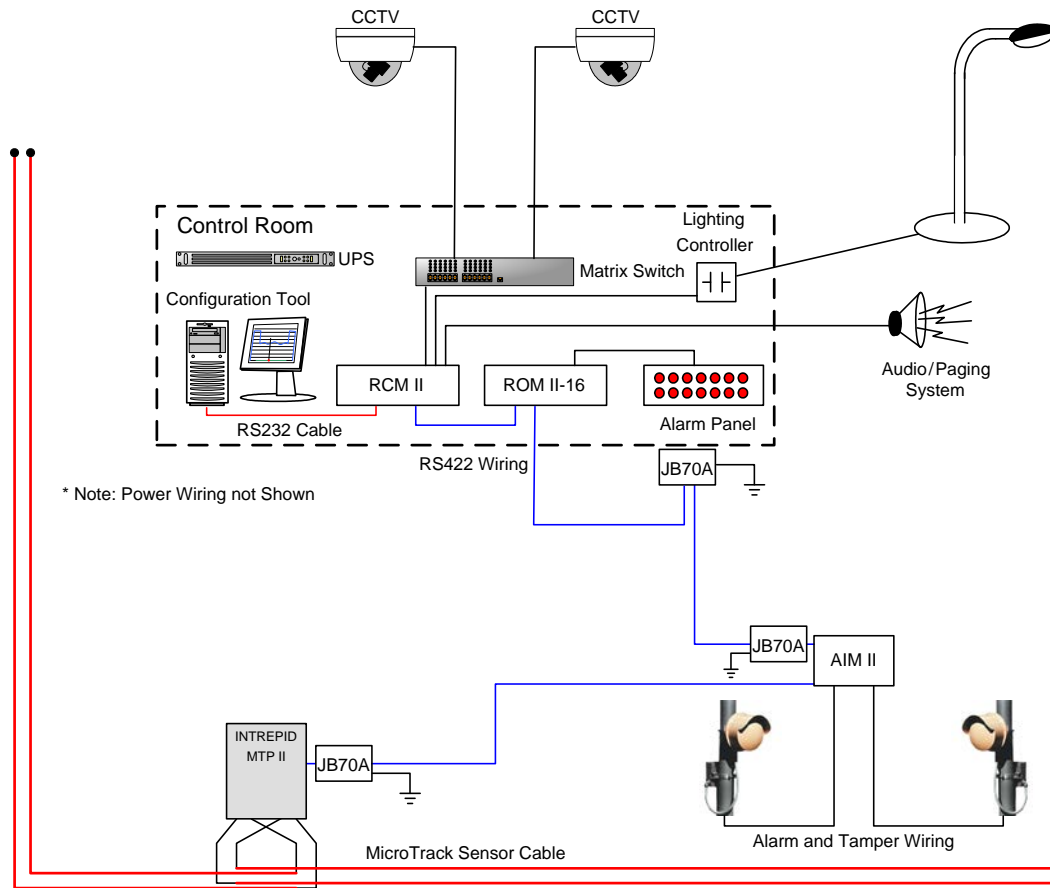

Figure 4 – Typical Configuration

3.0 Configuration Switch/Jumper

3.1 Introduction

There is one 8-position dip switch (S1) on the ROM II-8 and ROM II-16 which is labeled ADDRESS. This switch is used to set the address that is used for alarm polling by one of the INTREPID™ Series II controllers. Jumper J2 is used to set the Communications Dropout Time (CDT) of the ROM II. This is the time duration that the ROM II uses to declare a communications failure from not receiving poll requests and drops out all relays.

3.2 Address Switch S1

Switch S1 is used to set the address of the ROM II which is used for the alarm polling by one of the INTREPID Series II controllers (RCM II, CM II, CM II-N, GCM II-HD, PSM, RPM II or SDK). The address can be set from 0 to 239. Switch S1, as shown in Figure 5, is set by using the **LSB (Least Significant Bit)** as the binary reference starting point for address 1.

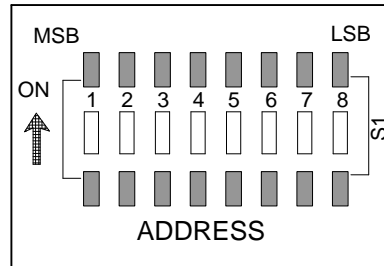

Figure 5 – Address Switch S1

3.3 CDT Jumper J2

Jumper J2 is used to set the Communications Dropout Time (CDT). There are four (4) timeout values that can be set as shown in Figure 6: 1) jumpers 1 to 2 = 30 seconds, 2) jumper 1 = 10 seconds, 3) jumper 2 = 3 seconds and 4) jumper 1 & 2 = no comfail. *If no jumpers are connected the timeout will be 30 seconds.* These times will set the ROM II to declare a communications failure and drop all relays out of service. All LED's will be illuminated once the communications failure is declared. *The default setting is 30 seconds.*

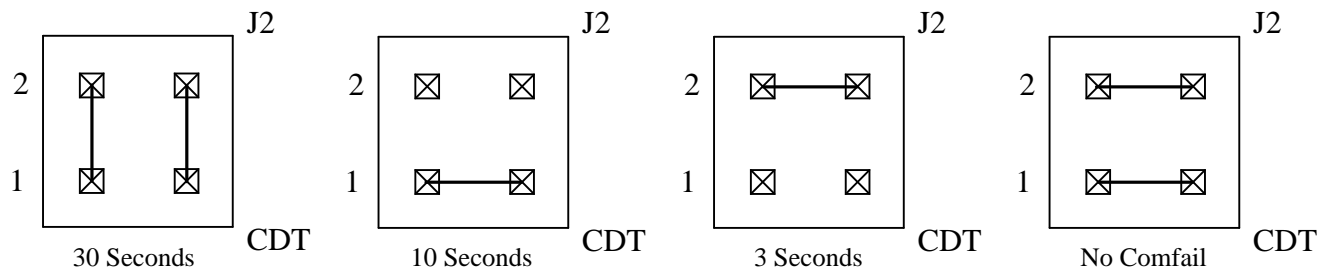

Figure 6 – CDT Jumper J2

3.4 Tamper Switch

A tamper switch located at the top of the circuit board (shown in Figure 2) is activated when the enclosure lid is removed. If the ROM II is installed in a different enclosure, an external tamper switch can be connected to the two pins located immediately to the right of the on board switch. They are labelled XSW1 and XSW2. The external switch should be wired so that the contacts are shorted when the enclosure is closed.

Do not apply power until all communications wiring and switch/jumper settings have been configured.

